

# PHILCO . . . . . Dial Drive Assemblies

**SERVICE BULLETIN**  
**No. 231**



**For Members of RADIO MANUFACTURERS SERVICE**

**A PHILCO SERVICE PLAN**

Model	Type Drive	Illus.	Complete Drive Assy.	Drive Cord	Drive Cord Spring	Dial	Inverted Dial	Dial Hub Assy.	Drive Bracket	Drive Ring and Hub
4	Friction		03011			03890				
14	Cable		31-1065	04834	7776	31-1066	31-1118			
15	Cable		4016A	4020A	7776	4276				
16 (Code 121-2-3)	Friction (Rubber)	"R"	45-2149			31-1058	31-1115			
16 (Code 125-6-7)	Cable & Vernier	"B"	31-1280	31-1352	28-8245	31-1363	31-1420			
17	Cable		31-1065	04834	7776	31-1066	31-1095			
18	Cable		31-1065	04834	7776	31-1066 31-1207*	31-1241			
19	Cable		31-1119	06920	7776	31-1025	31-1024			
20-21	Friction		45-2150			4209B				
28	Cable & Vernier	"D"	31-1186	31-1457	7776	31-1208				
28CSX	Cable	"C"	31-1276	31-1457	7776		31-1481			
29	Cable & Vernier	"A"	31-1187	31-1457	7776	31-1208				
29	Cable & Vernier	"C"	31-1276	31-1457	7776	31-1245	31-1481			
30	Cable		4016A	3484A	3012	4139 (Scale)				
32	Cable		31-1074	31-1457	7776	31-1025				
34	Friction (Rubber)	"R"	45-2149			31-1162				
35-36	Friction		03011			03031				
37	Friction		03430			05811				
38	Vernier	Types "O," "S," and "T" used on this model—see illustration					31-1084			
39	Vernier	Types "O," "S," and "T" used on this model—see illustration					31-1471			
40-41-42	Cable		3393A	3484A	3012	3794				
43	Cable		05365	4020A	7776	05418				
44	Friction (Rubber)	"R"	45-2149			31-1107				
45	Cable & Vernier	"D"	31-1186	31-1457	28-8252	31-1208				
45	Cable & Vernier	"F"	31-1275	31-1457	28-8252	31-1208				
46	Friction		45-2150			4209B				
47	Cable		04835	04834	7776	04832				
48	Friction		45-2151			05811				
49	Cable & Vernier	"J"	45-2152	31-1456	7776	31-1205				
50	Friction		06522			03322				
51-52	Friction		45-2150			04031				
54	Vernier	Types "P" and "Q" used on this model—see illustration.					27-5008			
58-59	Vernier	Types "P" and "Q" used on this model—see illustration.					27-5051			

INVERTED DIAL SCALES ARE USED ON ALL MODELS HAVING CABINET IDENTIFICATION AS FOLLOWS: CSX; LZ; LZ; RX; AND MODEL 660L.

\* Covers Police Frequencies.

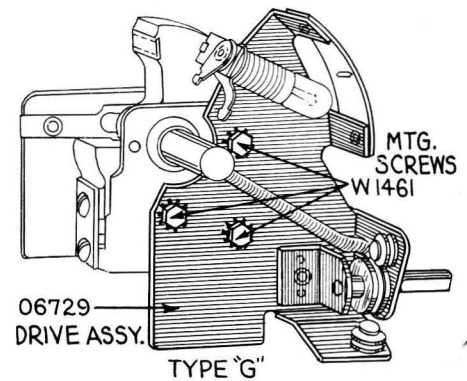
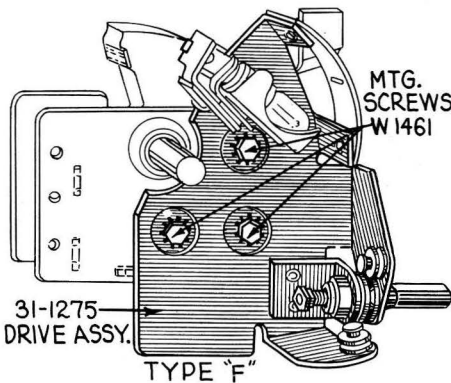
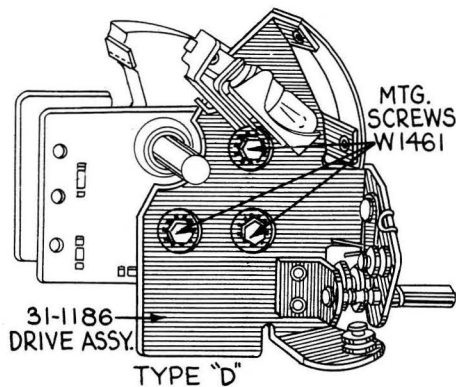
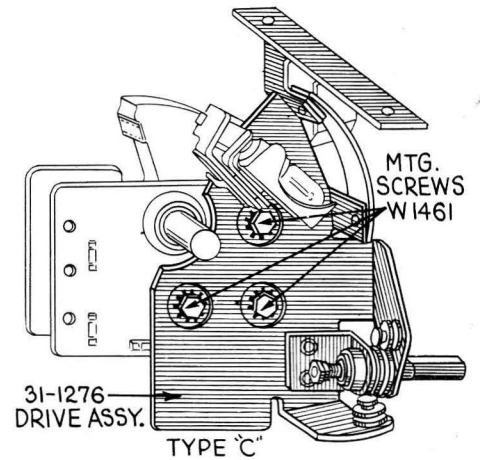
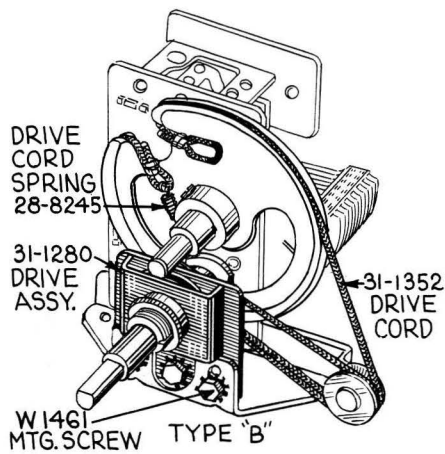
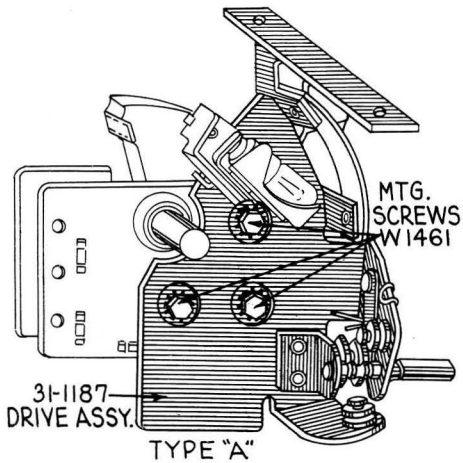

W-520		W-481	
DIAL SET SCREWS			
	4020A		17 1/2"
	04834		17"
	31-1352		16 1/2"
	3484A		15 3/4"
	31-1457		15 3/4"
	06920		15 1/2"
DIAL DRIVE CORDS			

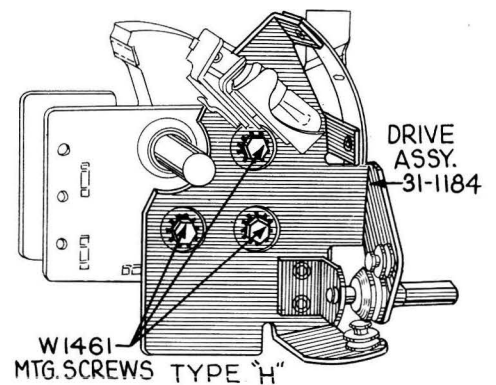

Here is complete information on dial drives for all Philco Models. This bulletin also contains a list of other miscellaneous parts such as dials, dial set screws, mounting screws and drive cords.

Illustrations of the various types of drives are provided to facilitate selecting the correct replacement assembly for models on which more than one type drive was used. These illustrations are listed by letters in the third column of the table.

To use this bulletin correctly, first locate the model number of the set being repaired. It will be found in the first column. If the model has more than one type drive, it will be listed more than once. Next, follow across to the third column for the number of the illustration. If no illustration is shown, use the assembly number in the fourth column. If an illustration is indicated, refer to pages 2 and 3, and use the assembly number of the drive that is identical to the drive assembly being repaired.

We recommend the replacement of the entire drive assembly in all cases if it is defective. This will insure a smooth working dial, plus long life.

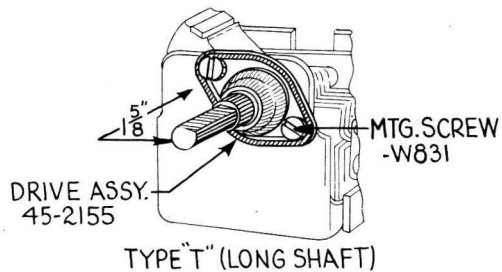
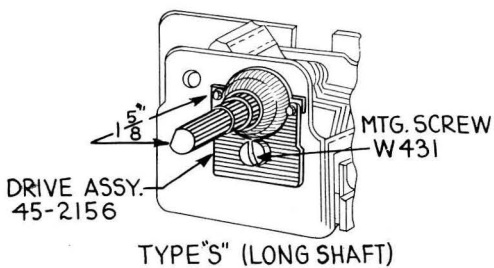
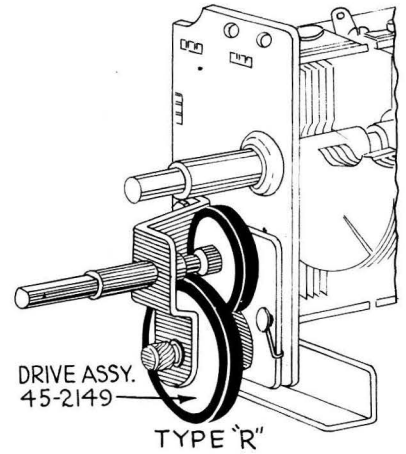
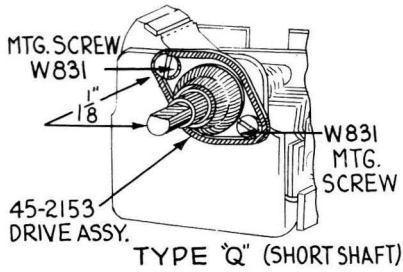
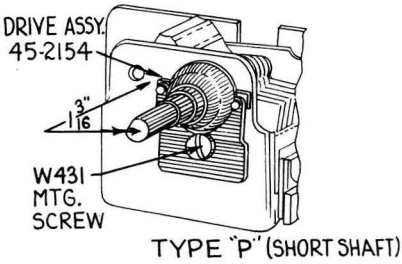
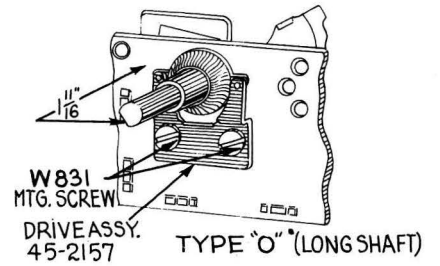
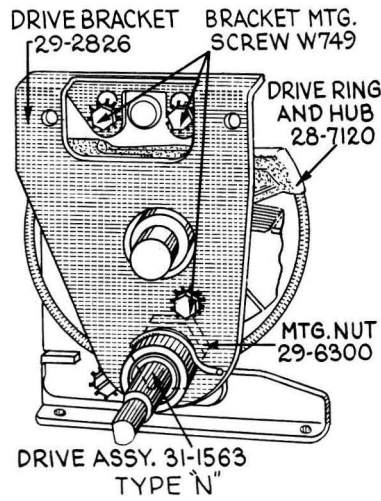
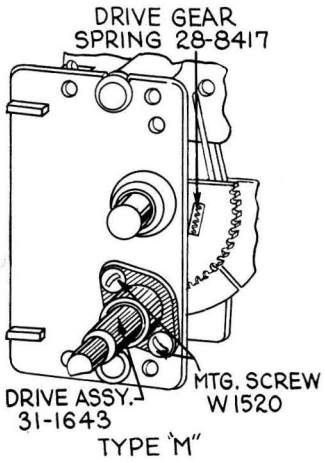
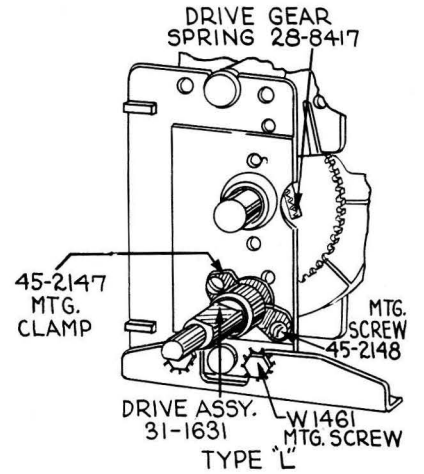
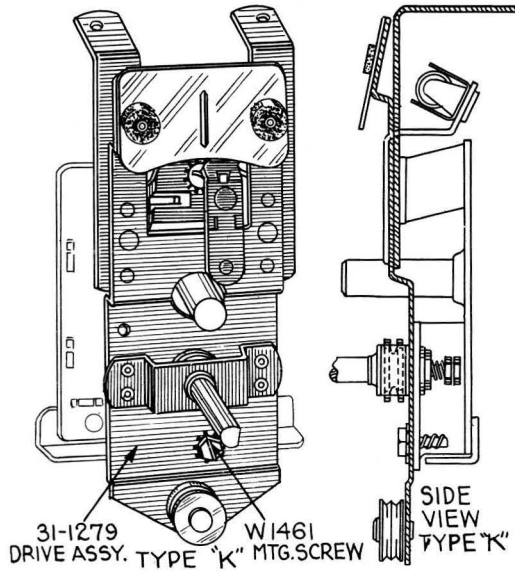
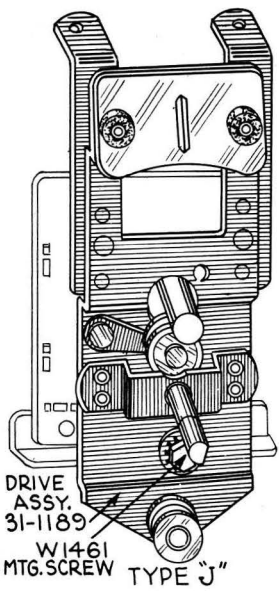

Model	Type Drive	Illus.	Complete Drive Assy.	Drive Cord	Drive Cord Spring	Dial	Inverted Dial	Dial Hub Assy.	Drive Bracket	Drive Ring and Hub
60	Vernier	Types "O," "S," and "T" used on this model—see illustration				31-1090 31-1472A				
65	Cable		3393A	3484A	3012	3398 (Scale)				
66	Vernier	Types "O," "S," and "T" used on this model—see illustration				31-1234				
70	Friction		03011			03031				
71	Friction		04835			04832	05992			
76	Cable		3393A	3484A	3012	3794 (Scale)				
77	Cable		4016A	4020A	3012	4118				
86-87	Cable		4016A	3484A	7776	3047 (Scale)¶				
89	Cable	"G"	06729- 06802‡	31-1157	7776	06697				
89	Cable	"H"	31-1184	31-1157	3012	31-1590				
90	Friction		03011			03031				
91	Cable		04836	04834	7776	04832	31-1026			
95	Cable		3393A	3484A	3012	3794 (Scale)				
96	Cable		4016A	4020A	7776	4118				
97	Cable & Vernier	"B"	31-1280	31-1352	28-8245	31-1513				
111-112	Cable		4016A	4020A	7776	4276				
116	Vernier	"N"	31-1563			27-5107		28-7129	29-2826	
118	Cable & Vernier	"J"	45-2152	31-1456	7776	31-1205	31-1241			
118	Cable & Vernier	"K"	31-1279	31-1456	7776	31-1414				
144	Cable & Vernier	"B"	31-1280	31-1352	28-8245	31-1206				
200	Cable		31-1065	31-1456	7776	31-1255				
201	Cable & Vernier		31-1382	31-1456	7776	31-1205				
610	Vernier	"L" or "M"	31-1643			27-5131		31-1550		
611	Vernier	"L" or "M"	31-1643			27-5097		31-1550		
620	Vernier	"L" or "M"	31-1631			27-5098		31-1550		
623	Vernier	"L" or "M"	31-1643			27-5097		31-1550		
624	Vernier	"L" or "M"	31-1643			27-5163		31-1724		
625	Vernier	"L" or "M"	31-1631			27-5098		31-1550		
630-635	Vernier	"L" or "M"	31-1631			27-5098	27-5121	31-1550		
640	Vernier	"N"	31-1563			27-5103	27-5122	31-1550	29-2826	28-7120
641	Vernier	"N"	31-1563			27-5125		31-1550	29-2826	28-7120
642	Vernier	"L" or "M"	31-1631			27-5098		31-1550		
643	Vernier	"N"	31-1563			27-5124		31-1550	29-2826	28-7120
645	Vernier	"N"	31-1563			27-5165		31-1724	29-2826	28-7120
650	Vernier	"N"	31-1563			27-5103	27-5122	31-1550	29-2826	28-7120
651	Vernier	"N"	31-1563			27-5170		31-1724	29-2826	28-7120
655	Vernier	"N"	31-1563			27-5165		31-1724	29-2826	28-7120
660-665	Vernier	"N"	31-1563			27-5115	27-5123	28-7129	29-2826	28-7120
680	Vernier	"N"	31-1563			27-5127		28-7129	29-2826	28-7120

‡ With shadow meter bracket.

¶ Model 87—Dial scale No. 3398.

# PHILCO

## Parts and Service Division